



Digital Video Signal Processor

DPTV™3DPRO

OVERVIEW

The DPTV™3DPRO is Trident's third generation DPTV single-chip mixed-signal video processor product. It integrates a high performance, multi-region 3D digital comb video decoder, a motion and edge adaptive de-interlacer with film mode recovery, scan rate and frequency conversion circuitries, and a graphical-based OSD for full support of today's premier digital TV applications. DPTV™3DPRO uses Trident's patented Unified Memory Architecture (UMA), which allows both 3D comb filter video decoding and video enhancement processing to share the same frame buffer memory made up of high-speed and cost-effective PC graphic memory. Designed for maximum system design flexibility, DPTV™3DPRO integrates all video interfaces to support hybrid digital and analog TV chassis applications. DPTV™3DPRO is ideal for applications in Digital TVs, Plasma TVs, LCD TVs, and Set-top boxes, where high precision video processing and scan rate frequency conversion are required. The users of Trident's single chip DPTV™ video processor(s) will benefit from many features available while maintaining a price competitive advantage over the existing solution(s).

FEATURES

- Integrated NTSC/PAL/SECAM video decoder with motion adaptive 3D digital comb filter
- Automatic 3D and 2D mode switching
- Advanced Unified Memory Architecture
- Improved 2D filter to remove false color
- Film mode recovery with bad edit detection
- Interlaced and progressive scan refresh
- 14 Dynamic picture quality enhancements (14D)

- PAL/NTSC/SECAM video format support
- VBI/Closed Caption and V-chip
- Optional text/graphical OSD capability
- 3rd gen. motion & edge adaptive de-interlacing
- 3rd gen. picture edge smoothing & sharpness control
- MPEG2 digital video interface (ITU-R BTU 656)
- SVGA digital/analog overlay with OSD and PIP
- SXGA output support
- Internal line-lock PLL to genlock incoming video signal
- 16/20-bit LCD dithering
- PIP, POP, multi-picture, and panorama display modes
- Programmable zoom viewer
- Analog and digital fast blank for Teletext
- Linear and non-linear scaling
- DLTI-Gamma correction and alpha blending
- High-speed support and low-cost SDRAM/SGRAM
- High precision 10-bit ADC front end and 10-bit DAC
- Advanced dual channel Digital Noise Reduction Y/C
- Audio/video lip synchronization
- Simultaneous digital input and digital output
- Direct YPbPr output with 525P/625P copy protection
- 3.3 V and 2.5 V power supply
- Programmable skin color enhancement
- Adaptive Black and white extension
- Single chip: 208 LQFP package

- Component Input
- 8/16/20/24-Bit Digital RGB output
- One Analog RGB output
- Direct YPbPr output with 525P copy protection

DESCRIPTIONS

Motion Adaptive 3D Digital Comb Video Decoder With Programmable 5-Tap filter

- NTSC, PAL, and SECAM format support
- High precision 10-bit ADC analog front-end
- Motion adaptive 3D digital Y/C separation
- Programmable 5-tap comb filter, and 2D Y/C separation
- Signal intelligent 3D/2D transition algorithm
- Integrated VBI slicer for Closed Caption and V-chip
- Enhanced dual-channel, frame-recursive YC noise reduction

Motion & Edge Adaptive De-interlacing

- 3rd generation adaptive edge smoothing algorithm for enhancing image clarity and sharpness
- Advanced film mode recovery with fast response bad-edit detection
- Pixel-based motion and edge adaptive de-interlacing

Interlaced and Progressive Scan Refresh

- Programmable blank time--control optimal for HDTV format converter application
- Interlaced @ 60Hz to 100 Hz
- Progressive scan @ 50 Hz to 75 Hz

14D: Dynamic Picture Enhancements

- Dynamic luminance transience index
- Dynamic chrominance transience index
- Dynamic scan velocity modulation

INPUTS / OUTPUTS

- One Composite (CVBS), S-video input
- 8-bit video interface for external TV decoder input (CCIR/ITU-R 656 input)
- Selectable (shared input) SVGA/MPEG2 digital video input (CCIR/ITU-R BTU 656, 601)

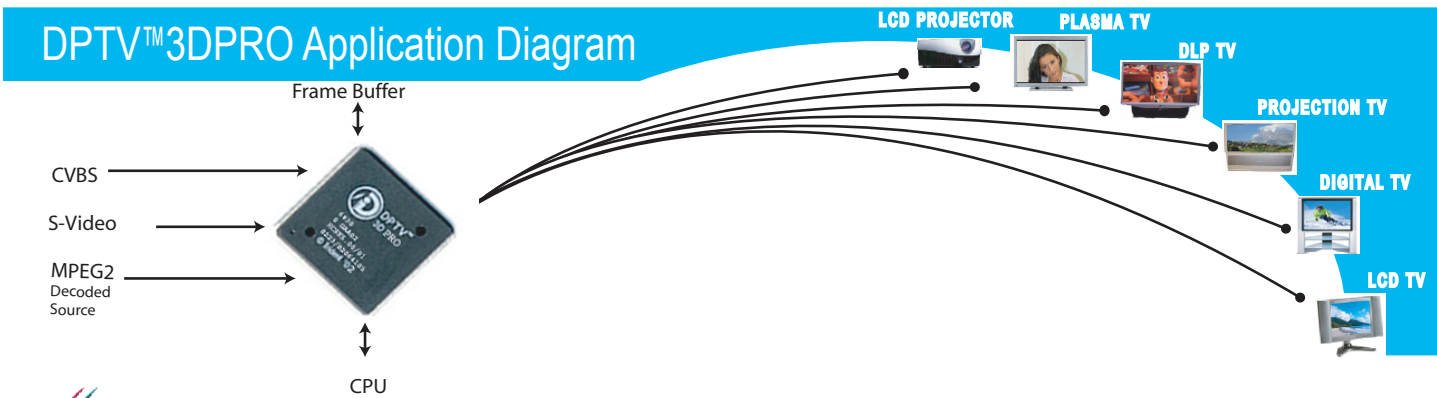



Digital Video Signal Processor

- Dynamic digital comb filter
- Dynamic motion & edge adaptive de-interlacing
- Dynamic temporal frame-filtering noise reduction
- Dynamic gamma control
- Dynamic black level extender
- Dynamic brightness/contrast adjustment
- Dynamic adaptive smoothing filter
- Dynamic frame/scan rate converter
- Dynamic white peak level restriction
- Dynamic room temperature color correction
- Dynamic digital SVGA overlay

Advanced Picture Processing

- Advanced linear and non-linear panorama scaling algorithms are applied to maximize the viewing experience in the various display modes.
- The programmable zoom viewer allows partial still pictures and live broadcast to be viewed in greater detail. This feature uses the technology available in the PIP and OSD features of the DPTV™3D.
- Alpha blending and overlay results in higher clarity and definition of objects of a picture while maintaining a more natural "look and feel" as it accounts for foreground and background colors.

- Picture controls such as hue, saturation, brightness, and contrast can be automatically adjusted to their optimal balance.
- Gamma correction.

OSD and (optional) VBI / Closed Caption

- Vertical Blank Interval (VBI) is a new industry standard for transmitting non-video data over the TV broadcast signal during the dead time (Vertical Blanking). Closed caption is also a non-video data that uses this portion of the transmission time.
- On-Screen Display (OSD). Users can choose to implement text-based OSD through the main CPU or graphical-based OSD through an optional OSD CPU.

Multi Screen Display Modes

- Picture-in-Picture (PIP). The PIP display mode is available with 16 different color frames for maximizing viewing experience. It can be repositioned to suit personal preferences and habits.
- Picture-Out-Picture (POP), multi-picture, cinema 1, and cinema 2 are some forms of dual program screening supported by the advanced architecture of the DPTV™. For multi-picture viewing, the screen is divided evenly into 4 or 9 smaller screens.

- Panorama viewing is best supported on a 16:9 aspect ratio screen. It is also supported on a 4:3 aspect ratio screen by downsizing the picture to fit the screen width. Other forms of downsizing are also available.

Software

- TDAPI-complete C-based API to customize user interface for fast time to market

Technical Support

- Evaluation Board
- Technical Reference Manual (TRM)
- Software Programmer's Guide (SPG)
- Application Notes
- White Papers

Complete Evaluation Kit

- Production-ready reference board supports the TDAPI development kit

Packaging

- 208-Pin LQFP
- Ordering part number is 6830

Trident DPTV™3DPRO Solution

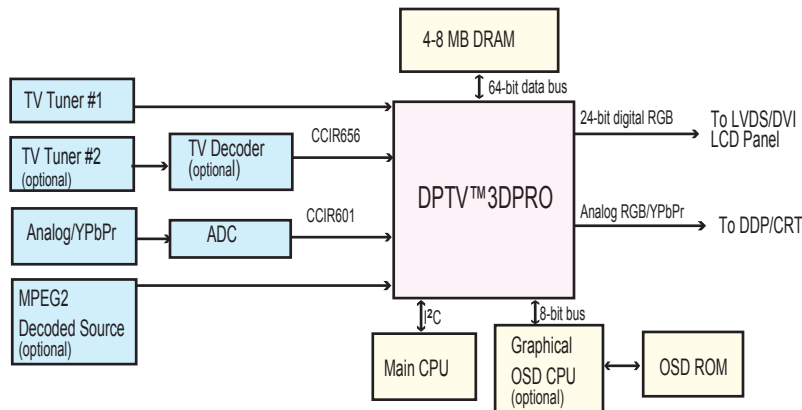

- Enhanced video features such as POP, Cinema 1, Cinema 2, OSD, etc., are controlled through the Micro-Controller.
- Minimum frame buffer RAM is 4MB for normal 3D operations, panorama, de-interlacing, or other advanced features.



USA

Trident Microsystems, Inc. (Headquarters)
 1090 East Arques Avenue
 Sunnyvale, CA 94085-4601, USA
 Phone: (408) 991-8800
 Fax: (408) 733-1438
 Web site: <http://www.tridentmicro.com>

Taiwan

Trident Technologies, Inc. Taiwan Branch
 3F. No. 51 Lane 188, Rueignang Rd.,
 Neihu, Taipei, Taiwan
 Phone: 886-2-2657-7686
 Fax: 886-2-2627-8727
 Web site: <http://www.trident.com.tw>

HongKong

Trident Microsystems (Far East), LTD.
 No. 2, 5/F., Futura Plaza,
 111-113 How Ming Street, Kwun Tong,
 Kowloon, Hong Kong
 Phone: 852-2756-9666
 Fax: 852-2796-9849